

VKF30

THERMOFORMING MACHINES



ENGLISH



IP 66
HYGIENIC
DESIGN



COMPACT



SMALL
COMPANY



36
MONTHS
GUARANTEE



TOOLS
FREE



STAINLESS
STEEL



USER
FRIENDLY



Types of packaging



Packaging products



VKF30: great quality in a small space

The automatic thermoforming machine VKF30, with its compact dimensions, was designed for packaging with rigid or flexible plastic material complying with the highest quality standards. Dedicated to small companies with requirements of packaging of food and medical products and consumer goods, it features the quality standards of a machine designed for large scale productions. Stainless steel structure aisi 304, brushless motor. Transportation of the plastic film with stainless steel pliers aisi 304, lifting system of sealing and forming moulds both mechanical and pneumatic. Control and management with control panel 7" touch screen. You can obtain packages in both flexible and rigid plastic material, therefore linear and perimetric cuts (shaped). User applications: sealing, skin with or without edge, MAP and vacuum.

VKF30

THERMOFORMING MACHINES

STRUCTURE AND DETAILS

Made in stainless steel to endure the hardest production environments and the most intense stresses. Aluminum inserts with anti corrosion and wear hard anodization treatment (anodic hard oxidation 40 µm).

WASHING AND SANITATION IN PRODUCTION ENVIRONMENTS

Designed to endure intense washing cycles and frequent sanitations with IP 66 protection level. Fits all production environments and all sanitation treatments.

FLEXIBLE AND VERSATILE IN MANAGEMENT AND FORMAT CHANGES

Fast management and format change without need of tools (tools free) and integration with other elements composing to packaging line.

GUARANTEE AND RELIABILITY

Complies with the highest quality standard both in terms of structure and of components, to the extent of having as many as 36 MONTHS GUARANTEE of standard guarantee.

AFTER SALE

Customer care at the international level for technical assistance, spare parts, complete revisions and support for the study of new packages or modifications to existing machines. System for the connection and monitoring of the machine with internet in protected network VPN.

ERGONOMIC AND USER FRIENDLY

Designed ergonomically guaranteeing wide range for the management of the format and mould changes as well as maintenance.

HMI MANAGEMENT INTERFACE

Easy to control thanks to a touch screen colour control panel, run by a HMI graphically intuitive and understandable at all control panel levels. Developed in Windows CE environment on SIEMENS SIMATIC systems.

ACCESSORIES

Oxygen analyzer, gas mixer, vacuum pumps, printer.

Dimensions

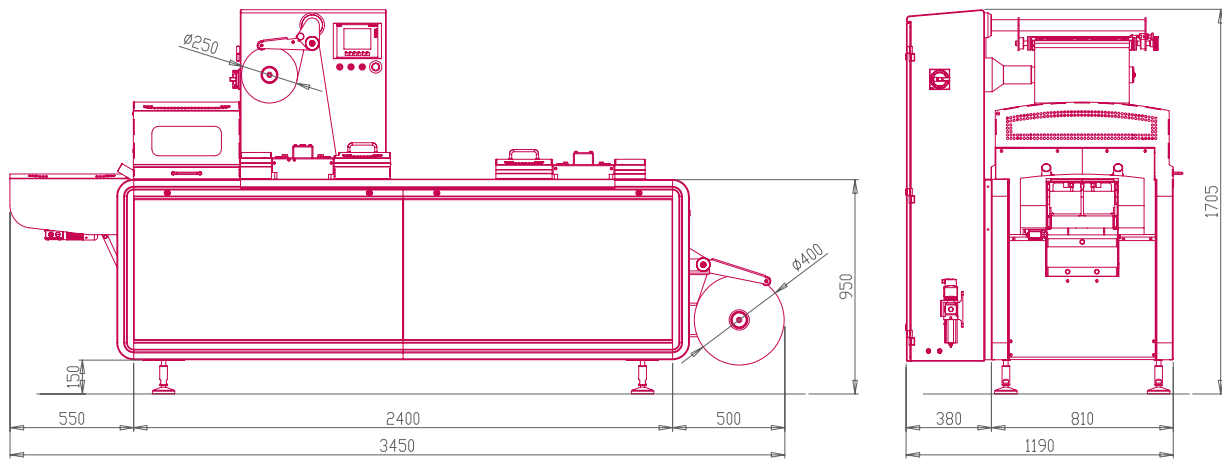

Technical characteristics

Machine length	from 3450 to 4650 with step of 600 mm	Pneumatic feeding (average consumption)	750 NI/min
Machine width	1190 mm	Electrical components	Siemens, Toshiba, ABB, Sick, Phoenix Contact
Machine height (luminous turret excluded)	1705 mm (± 50 mm)	Mechanical components	Rossi Motoriduttori, Minimotor, Siemens, Iwis, SKF, Igus
Loading area	600 ÷ 1600 mm	Pneumatic components	Festo, Parker
Loading area height	950 mm (± 50 mm)	Vacuum system components	Omval, Valvaut, Maros Engineering, Trelleborg
Machine weight (vacuum pump excluded)	1000 Kg		
Control panel height	1450 mm (± 50 mm)		
Lower film standard width	322 - 362 - 422 mm (+1 mm)		
Lower film special width	Not available		
Feeding max. step	300 mm		
Forming max. depth	120 mm		
Film reel core diameter	3" (70 ÷ 76 mm)		
Lower film reel max. diameter	400 mm		
Upper film reel max. diameter	250 mm		
Construction	STAINLESS steel Aisi 304		
Control / command system	PLC and Touch Screen 7"		
Control / command interface	HMI Simatic Siemens - Windows CE		
Feeding system (Drive)	Brushless Motor		
Installed power (pumps excluded)	9,5 kW - 440 V - 50/60 Hz - 3P+N+GND		
Protection degree IP / NEMA	IP 66 / NEMA 4		

Packaging

Production capacity	up to 10 cycles / min.
Application	Sealing - Skin - MAP - Vacuum
Lower film for RIGID packages	up to 500 µm
	PET - PVC - PS
Upper film for RIGID packages	Not available
Lower film for FLEXIBLE packages	up to 400 µm
	PA - PP - Paper - Alu
Upper film for FLEXIBLE packages	up to 200 µm
	PA - PP - Paper - Alu - Tyvec - Skin